

# *Smart Grid Concepts*

Presented to:

*Wyoming Infrastructure Authority*

June 24, 2009

**Don Collins**  
**Chief Executive Officer**  
**Western Research Institute**  
**365 North 9th Street**  
**Laramie, WY 82070**  
**307-721-2209**

**Western Research**  
I N S T I T U T E

- **North American Smart Grid**
- **NETL Modern Grid Initiative**
- **Technology Pipeline**
- **Wyoming Opportunities**
- **Things to Ponder**
- **Discussion**

- **GridWise<sup>®</sup> Architecture Council**
  - Articulate the goal of interoperability across the electric system
  - Identify the concepts and architectures needed to make interoperability possible
  - Develop actionable steps to facilitate the interoperation of the systems, devices, and institutions that encompass the electric system

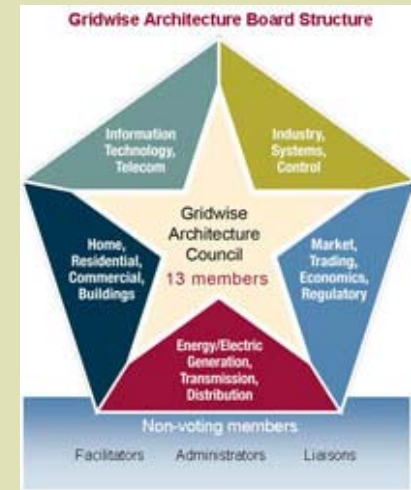

- **Domain Expert Working Groups**
- **EPRI Use Cases and IntelliGrid Architectures, Methodology & Tools**

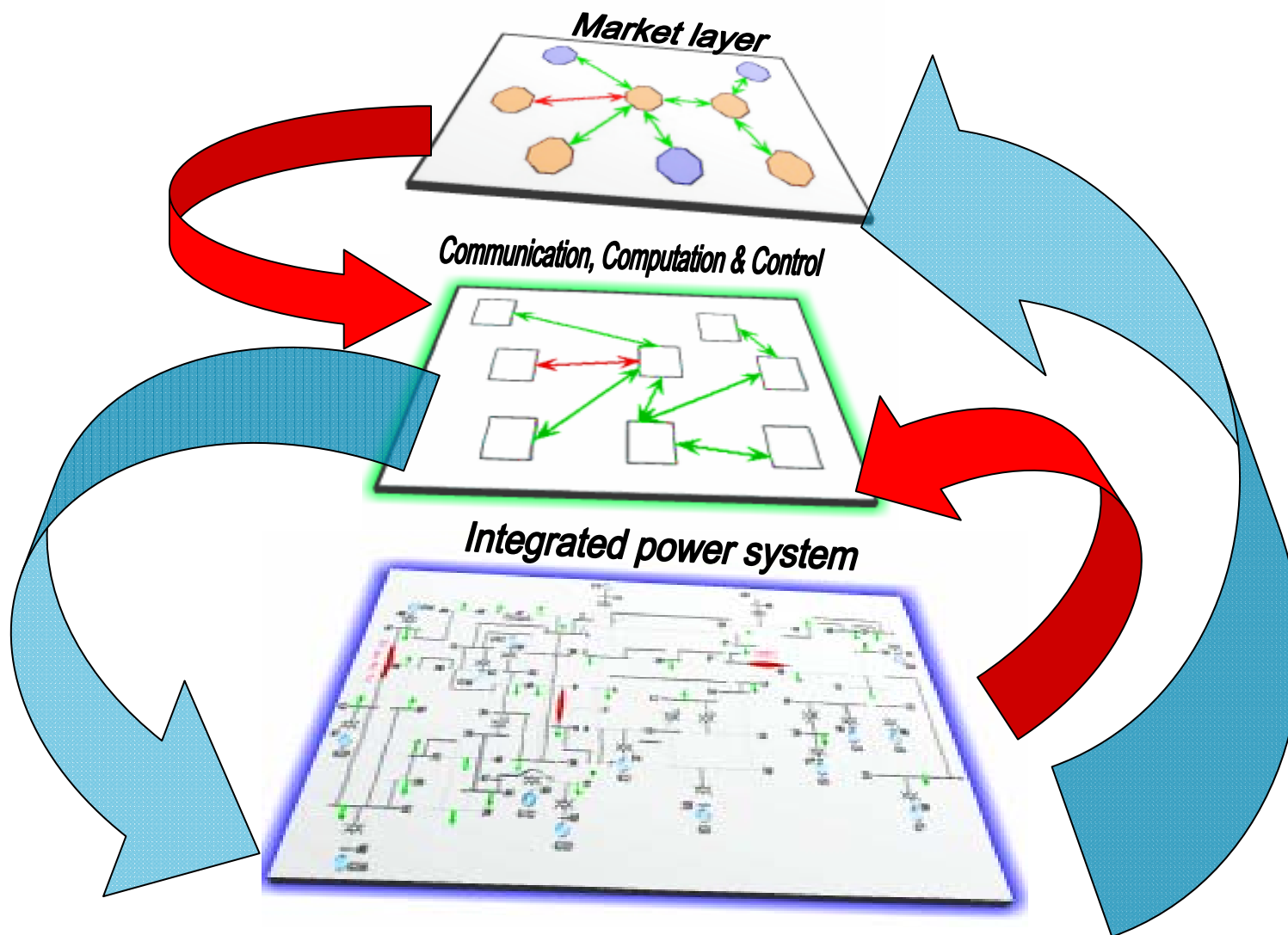

Source: West Virginia University, Advanced Power & Electricity Research Center

<b>Without a Smart Grid</b>	<b>With a Smart Grid</b>
<ul style="list-style-type: none"><li>▪ <b>&lt;13% variable renewables penetration</b></li><li>▪ <b>5% demand response</b></li><li>▪ <b>&lt;1% consumer generation used on the grid</b></li><li>▪ <b>47% generation asset utilization</b></li><li>▪ <b>50% transmission asset utilization</b></li><li>▪ <b>30% distribution asset utilization</b></li></ul>	<ul style="list-style-type: none"><li>▪ <b>&gt;30% variable renewables penetration</b></li><li>▪ <b>15% demand response</b></li><li>▪ <b>10% consumer generation used on the grid</b></li><li>▪ <b>90% generation asset utilization</b></li><li>▪ <b>80% transmission asset utilization</b></li><li>▪ <b>80% distribution asset utilization</b></li></ul>

Today's Grid	Principle Characteristic	Modern Grid
Responds to prevent further damage. Focus is on protection of assets following system faults.	Self Heals	Automatically detects and responds to actual and emerging transmission and distribution problems. Focus is on prevention. Minimizes consumer impact.
Consumers are uniformed and non-participative with the power system.	Motivates & includes the consumer	Informed, involved and active consumers. Broad penetration of Demand Response.
Vulnerable to malicious acts of terror and natural disaster.	Resists attack	Resilient to physical and cyber attack. Less vulnerable to natural disasters with rapid restoration capabilities.
Focused on outages rather than power quality problems. Slow response in resolving Power Quality (PQ) issues.	Provides power quality for the 21 <sup>st</sup> century needs	Quality of power meets industry standards and consumer needs. Various levels of Power Quality (PQ) at various prices.

NETL April 2007, "A Vision for the Modern Grid, Powering Our 21<sup>st</sup> Century Economy"

## *NETL Modern Grid Initiative*

Today's Grid	Principle Characteristic	Modern Grid
Relatively small number of large generating plants provide majority of generation. Numerous obstacles exist for interconnecting Distributed Energy Resources (DER).	Accommodates all generation and storage options	Very large number of diverse distributed generation and storage devices deployed to complement the large generating plants. "Plug-and-Play" convenience. Significantly more focus on and access to renewables.
Limited wholesale markets still working to find the best operating models. Not well integrated with each other. Transmission congestion separates buyers and sellers.	Enables markets	Mature wholesale market operations in place; well integrated nationwide and integrated with reliability coordinators. Retail markets flourishing where appropriate. Minimal transmission congestion.
Minimal integration of limited operational data with asset management processes and technologies. Siloed business practices. Time based maintenance.	Optimizes assets and operates efficiently	Greatly expanded sensing and measurement of grid conditions. Grid technologies deeply integrated with asset management processes to most effectively manage assets and costs. Conditions based maintenance.

# Impact of DER Penetration

% of Generation	≤ 2%	≤ 10%	≤ 30%	100%
<b>Grid Penetration Scenarios</b>	I. Low-numbers and level of PV with relatively stiff grid connection	II. Moderate-level of PV with relatively soft grid connection	III. High-level of PV with capacity of grid less than the load demand	IV. PV operates part time as an island or micro-grid
<b>PV Impact and its Role in the Grid</b>	Very low, not significant to grid operation	Non critical, can affect distribution voltage near PV	Critical to power delivery and meeting demand	Primary power source for stand alone operation
<b>Interconnection and Integration Objectives</b>	Non interference, good citizen and compatible	Manage any local distribution impacts	Engage PV for system operations and control	Rely on PV for stability and regulation
<b>Rules/Standard Operating Procedures</b>	IEEE 1547-2003 current practice radial feeders	Modified 1547, add network and penetration limits	New rules include operation and grid support requirement	Standalone rules that are system dependent
<b>Main Concerns with-respect-to system dynamic grid impacts</b>	<ul style="list-style-type: none"> <li>- Voltage and current trip limits,</li> <li>- Response to faults</li> <li>- Synchronization</li> </ul>	<ul style="list-style-type: none"> <li>- Interfere with regulation,</li> <li>- Recovery times,</li> <li>- Islanding</li> <li>- Coordination.</li> </ul>	<ul style="list-style-type: none"> <li>- Availability</li> <li>- Regulation provided - Ramping response</li> <li>- Interactions of machine controls</li> </ul>	<ul style="list-style-type: none"> <li>- Availability</li> <li>- Load following</li> <li>- Voltage control</li> <li>- Normal and reserve capacity</li> </ul>

.....Transitions On- and Off-Grid.....

Source: Dr. Tom Key, Electric Power Research Institute

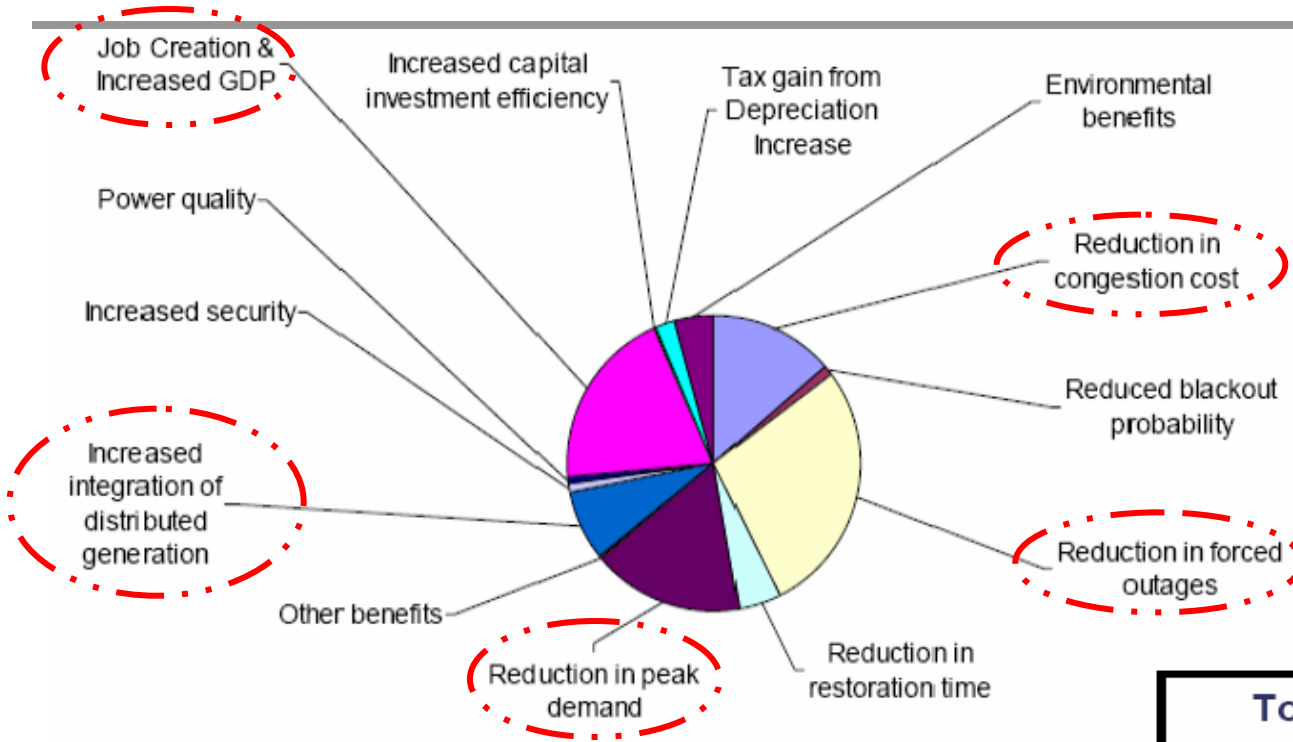

Source: San Diego Smart Grid Study, Energy Policy Initiatives Center, USD, October 2006

Regional  
"IRR" >26%

**WY Benefit?**

**“Based on the cost-benefit analysis conducted for this study, there appear to be sufficient benefits to the utility system, to the broader region (societal), and in total, to justify a movement of the San Diego regional grid to a Smart Grid architecture.” - Bottom Line from San Diego Smart Grid Study, October 2006**

<b>Total Annual Benefits</b>	<b>\$141M</b>
<b>System Benefits (20-years)</b>	<b>\$1,433M</b>
<b>Societal Benefits (20-years)</b>	<b>\$1,396M</b>
<b>Total Capital Cost</b>	<b>\$490M</b>
<b>Annual O&amp;M Cost</b>	<b>\$24M</b>

- **Dynamic Line Thermal Rating**
- **Smart Agent Autonomous Control**
- **Intelligent Universal Transformer and Inverters**
- **Interoperability – *The Enabler***
- **Modern Grid Key Technologies**
- **Cyber Security**

**INCREASING LINE UTILIZATION WHILE REDUCING RISK BY FIELD MEASUREMENT OF HIGH TEMPERATURE CONDUCTOR SAG & USE OF DYNAMIC "LOW RATING" WARNING METHOD**

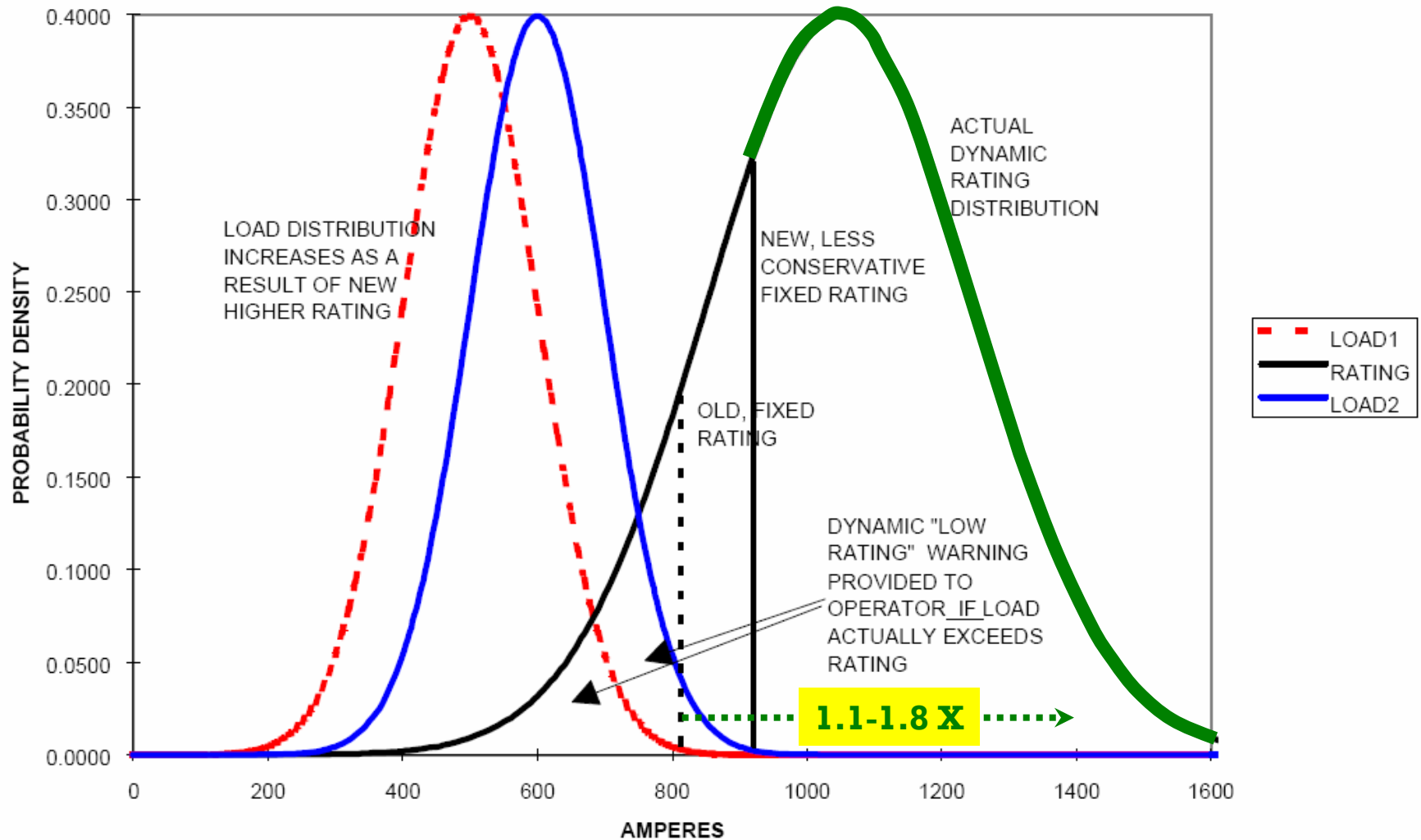

Source: D.A. Douglass, PDC, "Real Time Monitoring and Rating of Transmission Lines"

## Wind Farm Transmission Line Example – Southwestern MN Buffalo Ridge

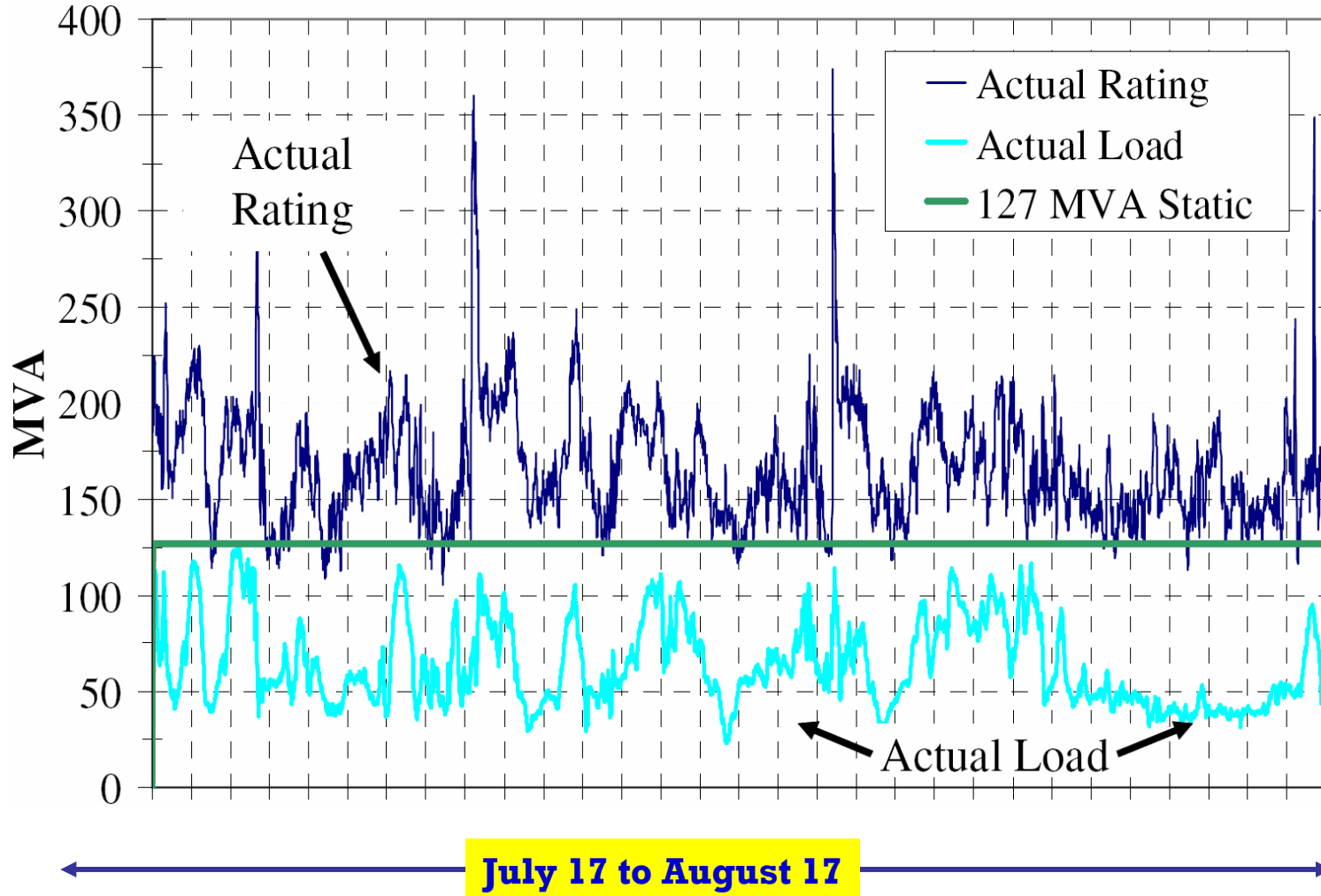

J. Assen et al, "Dynamic Thermal Rating System Relieves Transmission Constraint" IEEE 2006 ESMO

- Build upon agents developed for DoD/ONR electric ship R&D
- Adapt agent based system to terrestrial *dynamic* environments
- Self configuration & coordination
- Self and team awareness of capability
  - Health diagnostics & prognostication
  - Service readiness & deterioration
  - Partial vs. full availability
- Millisecond response for frequency stability
- Coordination with transmission synchronous phasor measurement unit systems
- Intentional Islanding
- Microgrid Control

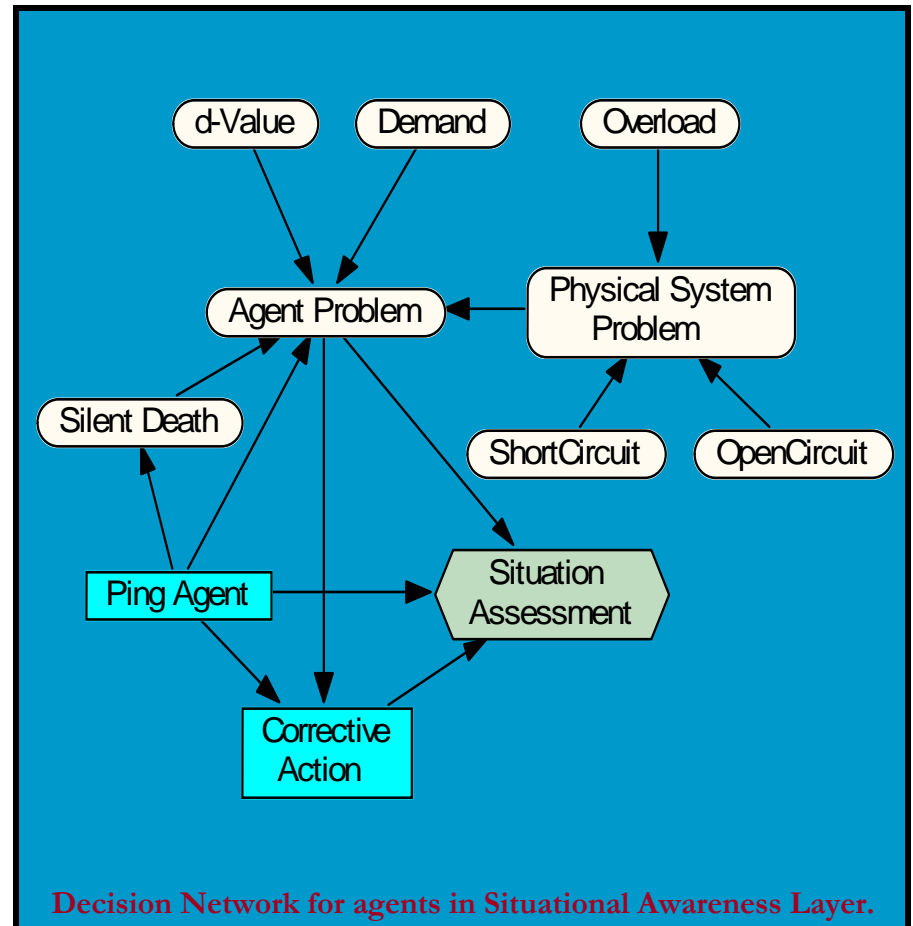

# Layered Control Architecture

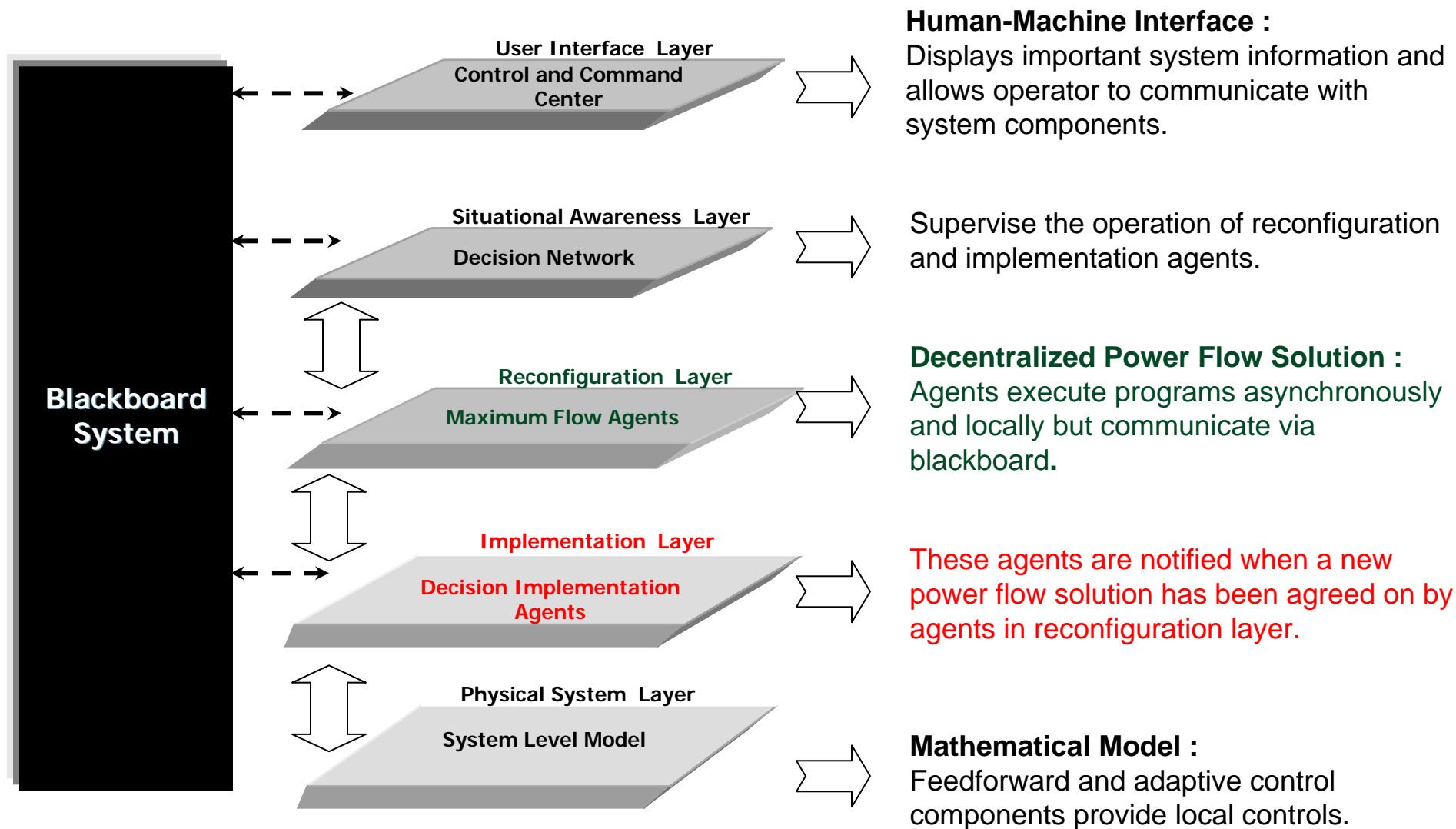

## EPRI Intelligent Universal Transformer

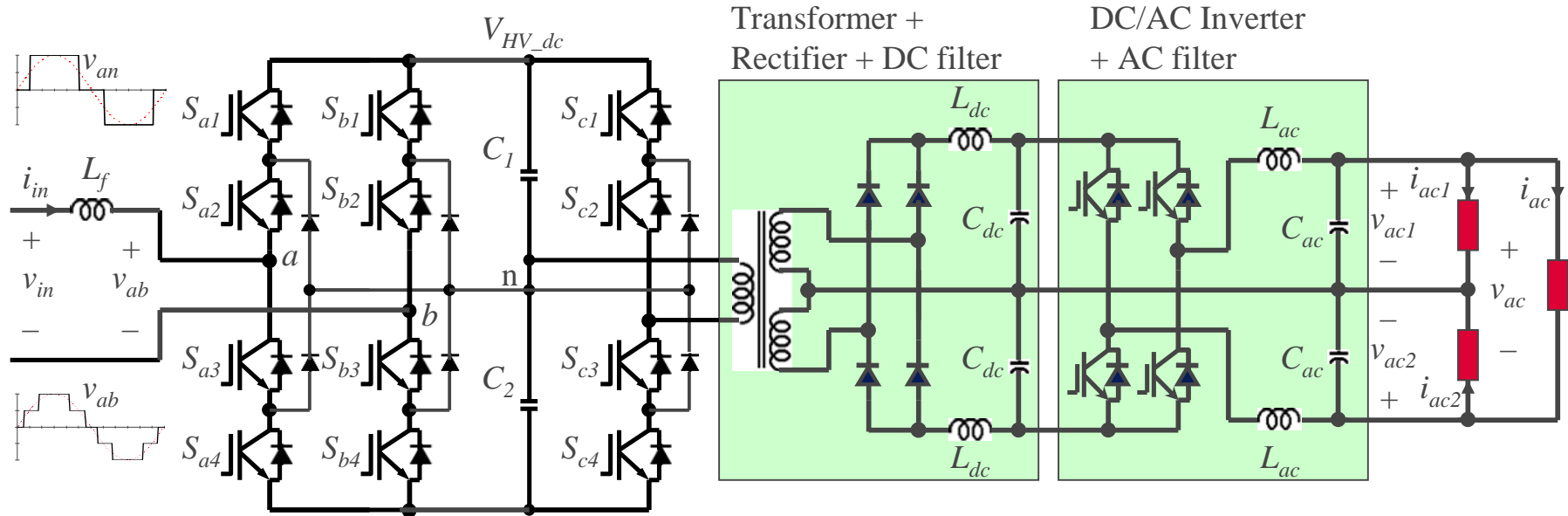

Integration of intelligent computer control with electronic “solid state” power switches.

Supports utility voltage, and also reduces harmonics and phase imbalances whether or not the DER is supplying energy.

$$\sqrt{I_{\text{real}}^2 + I_{\text{reactive}}^2 + I_{\text{harmonic}}^2 + I_{\text{balance}}^2}$$

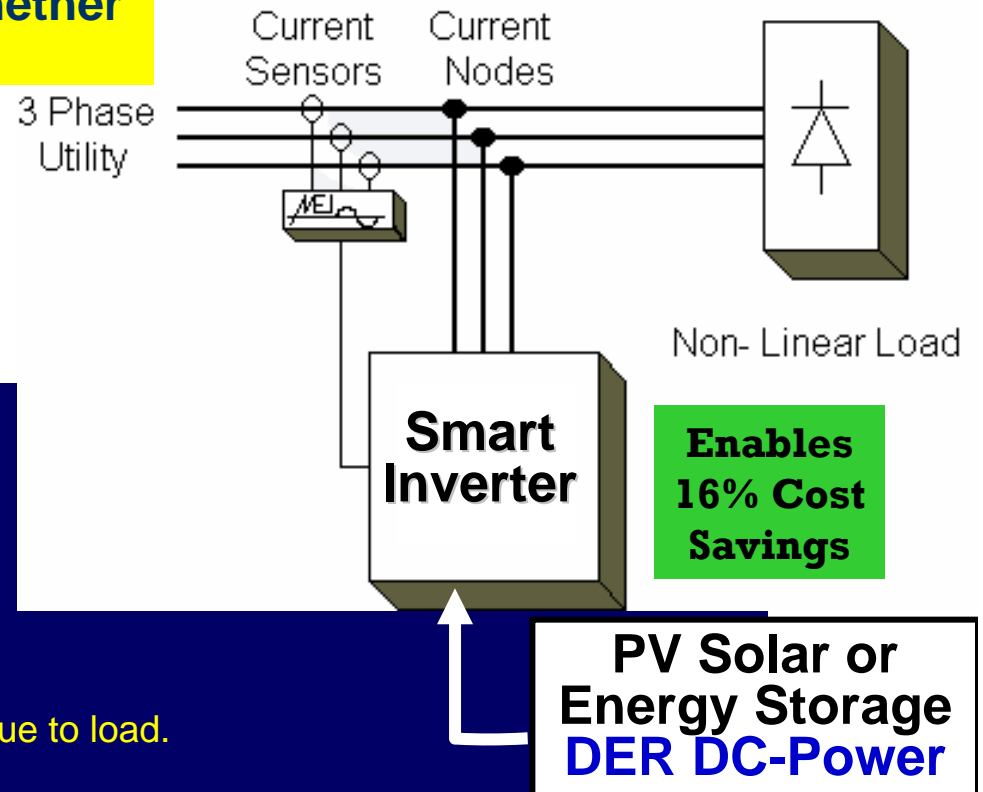

### Manage Power Quality via DER Inverter

- VAR Support (leading/lagging)
- Harmonics <1.5% THD
- Phase imbalance correction
- DER Voltage & Phase matching to utility circuit in real-time

Utility sees Unity power factor current flow on circuit due to load.

Intelligent priority control algorithm enables Utility or DER owner to emphasize/ select order of priority for specific application or operating condition.

Provides flexibility to satisfy the load non-linear current needs during DER Intentional Islanding and MicroGrid operational scenarios.

# Voltage Support without VARs

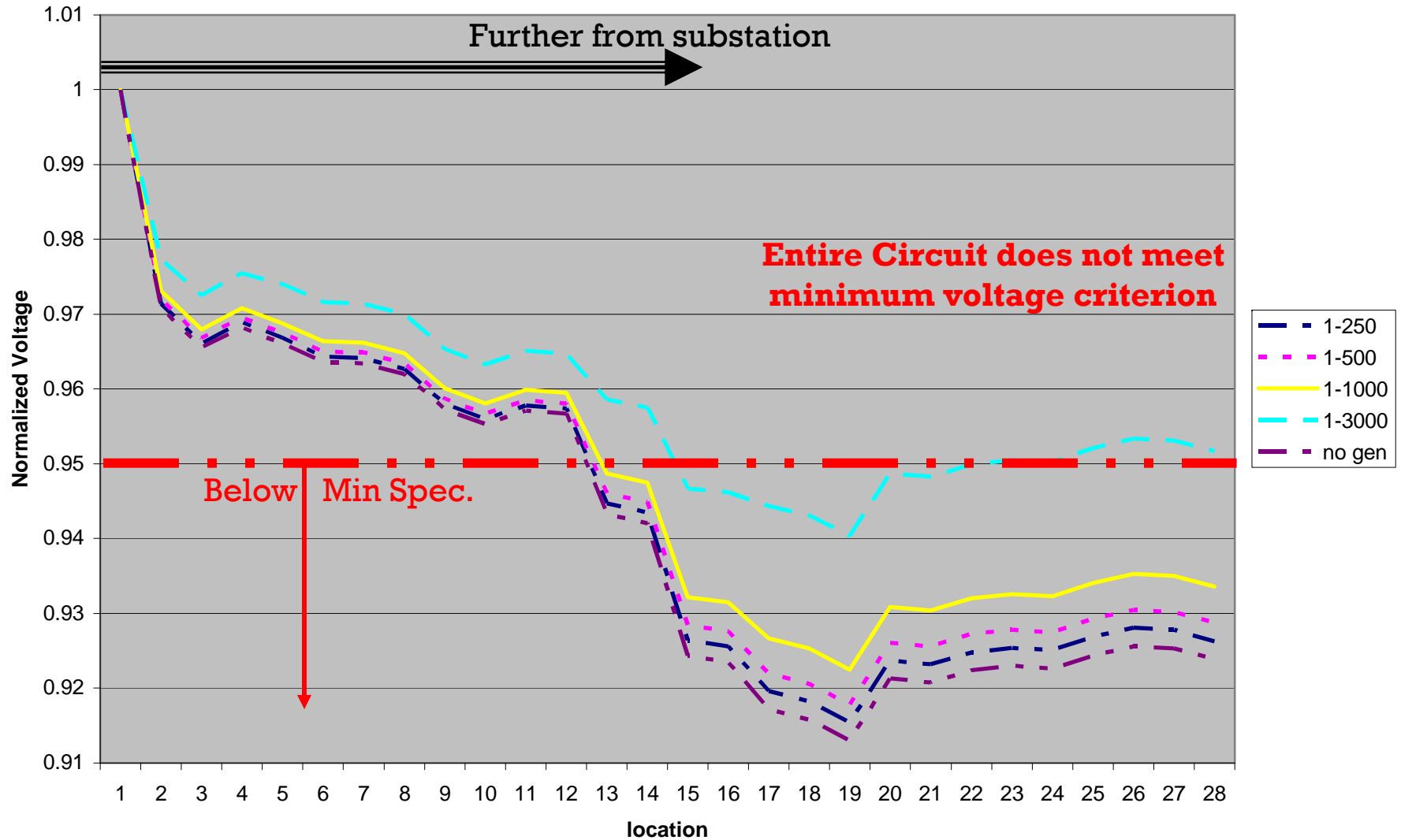

Source: C.A. Hessenius, A. Ang and S. Hamilton, "Fuel Cells: A Utility Perspective", ASME Fuel Cell Conference 2006, Irvine, CA

# Voltage Support with VARs

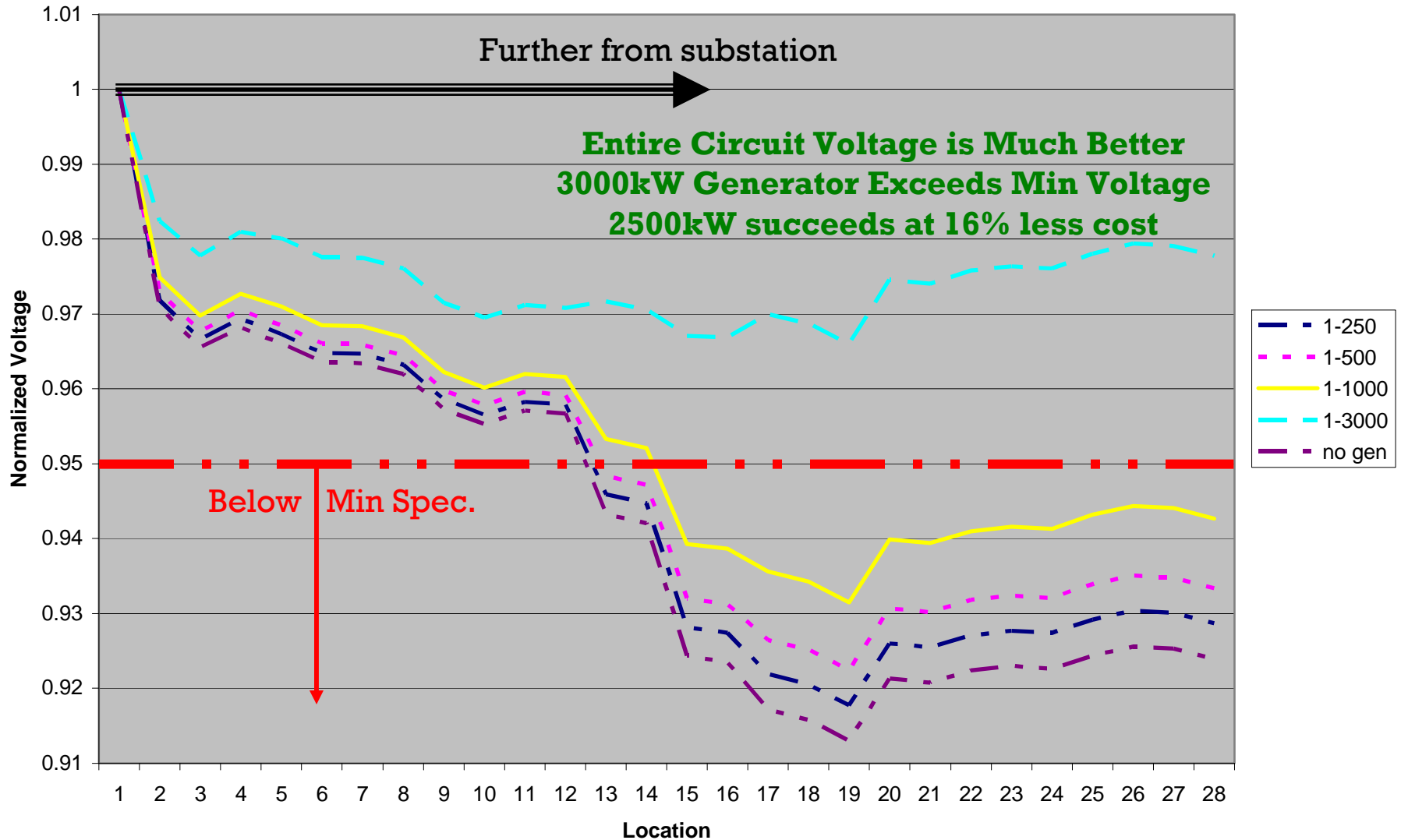

Source: C.A. Hassenius, A. Ang and S. Hamilton, "Fuel Cells: A Utility Perspective", ASME Fuel Cell Conference 2006, Irvine, CA

## The Modern Grid Initiative

### The Modern Grid Initiative: A Systems View of the Modern Grid

#### Appendix A Series: Principal Characteristics

- A1 Self-Heals
- A2 Motivates and Includes the Consumer
- A3 Resists Attack
- A4 Provides Power Quality for 21st Century Needs
- A5 Accommodates All Generation and Storage Options
- A6 Enables Markets
- A7 Optimizes Assets and Operates Efficiently

#### Appendix B Series: Key Technology Areas

- ← B1 Integrated Communications
- ← B2 Sensing and Measurement
- ← B3 Advanced Components
- ← B4 Advanced Control Methods
- ← B5 Improved Interfaces and Decision Support

- **Interoperability** – the capability of two or more networks, systems, devices, applications or components to exchange information between and to use the information so exchanged.
- Enables the vast scale interoperability necessary to transform electric power operations into a system that integrates markets and technology to enhance our socio-economic well-being and security.

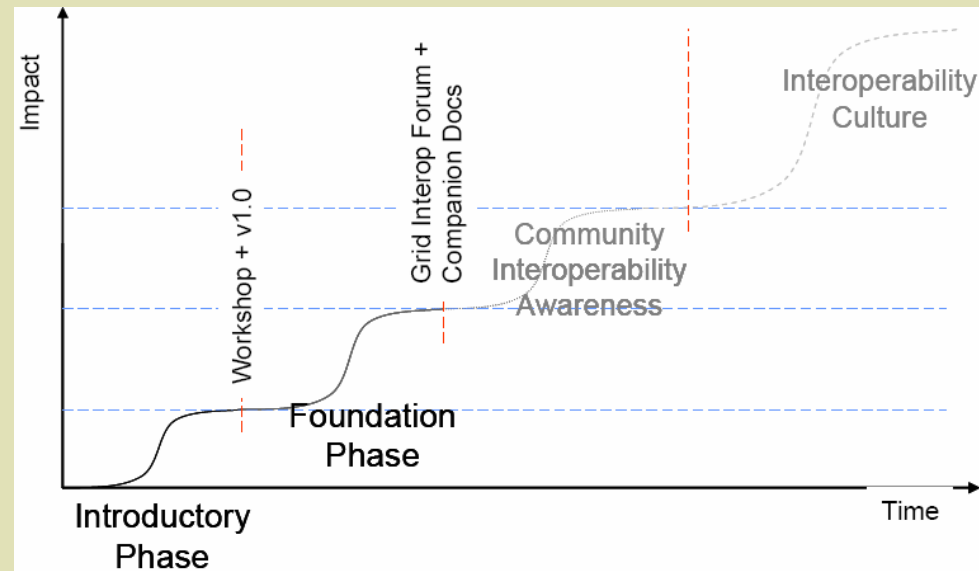

- **Dynamic transmission line rating**
- **Synchronous phasor measurement units (PMUs)**
- **Energy storage to support WY wind**
- **Wind Hybridization w/ fossil plants**
- **Wind to move WY fossil up value chain**
- **Influence as Energy Central USA**

- **Rate of DER penetration and energy efficiency impact on central power and transmission needs**
- **Wyoming Energy Policy to shape National Energy Policy**
- **Regulatory and business model changes coming and needed**
- **Central energy storage vs. local**
- **Cross utility smart grid autonomous control coordination and data sharing**
- **New workforce skills – *IT, Electronics***

- **Questions?**
- **Comments?**